

THIS DRAWING IS UNPUBLISHED. RELEASED FOR PUBLICATION, 19 .
 © COPYRIGHT 19 BY AMP INCORPORATED. ALL INTERNATIONAL RIGHTS RESERVED.

LOC	DIST	P	F	ZONE	LTR	REVISIONS	DATE	APPD
G	86				G	REVISED PER 0720-0160-94	6/23/94	OKS AJK

METRIC
 DIMENSIONS LISTED IN mm [INCHES]

- 1 STAMP CHARACTERS APPROX AS SHOWN
- 2 MATERIAL THK: 2.59 ± 0.05 [.102 ± .002]

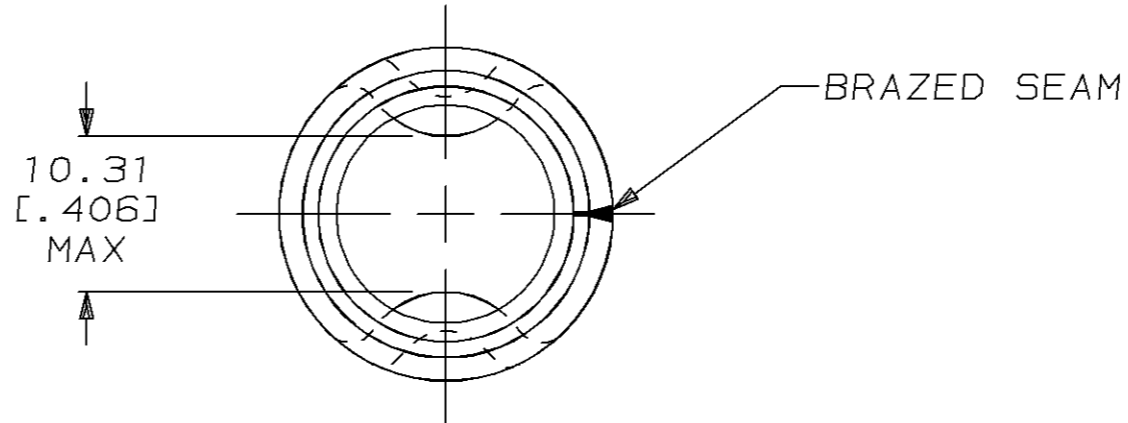
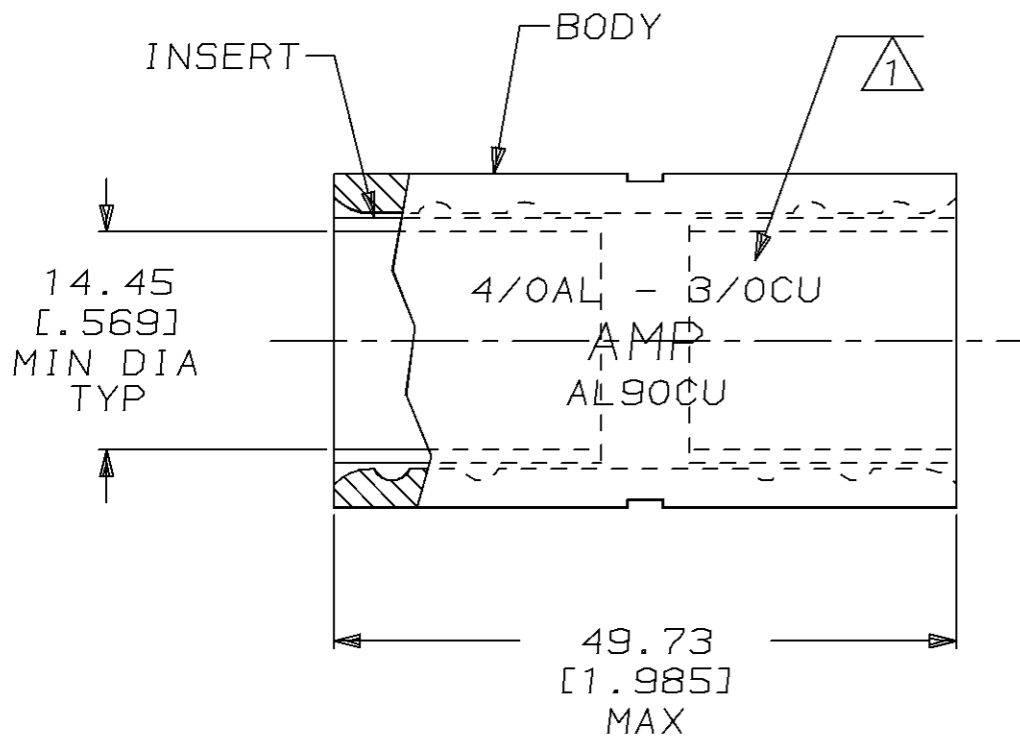
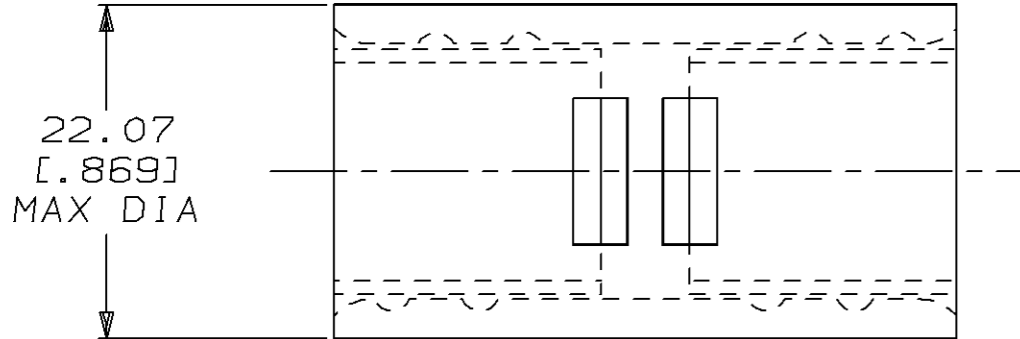

BODY: COPPER 1.83^{±0.10} [.072^{±.004}] ASTM B-152
 TIN PL 0.00254 [.000100] MIN THK PER MIL-T-10727

INSERT: BRASS MIL-C-50
 TIN PL 0.00762 [.000300] MIN EXT THK PER MIL-T-10727

52019

AMP INCORPORATED CUSTOMER SERVICE SYSTEMS	
FOR ADDITIONAL PRODUCT INFORMATION OR COPIES OF DRAWINGS AND TECHNICAL DOCUMENTS	PRODUCT INFORMATION CENTER 1-800-522-6752
FOR APPLICATION TOOLING INFORMATION	TOOLING ASSISTANCE CENTER 1-800-722-1111
FOR ORDER ENTRY	1-800-526-5142

MAX RECOMMENDED OPERATING TEMPERATURE:
 170° MAX

VOLTAGE RATING:
 NOT APPLICABLE

WIRE CROSS SECTIONAL AREA RANGE:
 96.3-117.0mm² [190,000-231,100] CIR MILS
 SOLID OR STRANDED

THIS DRAWING IS A CONTROLLED DOCUMENT FOR AMP INCORPORATED. IT IS SUBJECT TO CHANGE AND THE CONTROLLING ENGINEERING ORGANIZATION SHOULD BE CONTACTED FOR THE LATEST REVISION.

DO NOT SCALE PRINT. UNLESS SPECIFIED	DR 2/5/94 DK SCHRUM
DIMENSIONS IN mm [INCHES] TOLERANCES ON: 2 PLC DEC ± 0.20 [.008] 3 PLC DEC ± - ANGLES ± -	CHK 2/7/94 AJ KAUFMAN
MATERIAL COPPER PER ASTM B-152 ANNEALED	APPD 2/7/94 RE ROSER
FINISH TIN PLATE 0.00254 [.000100] MIN THK PER MIL-T-10727	APPD 2/7/94 JL MECKELY
	PRODUCT SPEC -
	APPLICATION SPEC -
	WEIGHT -

AMP AMP Incorporated Harrisburg, PA 17105-3608		
NAME WIRE SPLICE, COPALUM™ - STRANDED/SOLID, WIRE SIZE: 4/OAL-3/OCU		
SIZE B	CAGE CODE 00779	DRAWING NO C-52019
SCALE 2:1	SHEET 1 OF 1	