

THIS DRAWING IS UNPUBLISHED. RELEASED FOR PUBLICATION ,19 .  
 © COPYRIGHT 19 BY AMP INCORPORATED. ALL RIGHTS RESERVED.

LOC		DIST		REVISIONS			
P	LTR	DESCRIPTION		DATE	DWN	APVD	
	J	REVISED PER 0L20-0178-97		03NOV97	DKS	CHK	

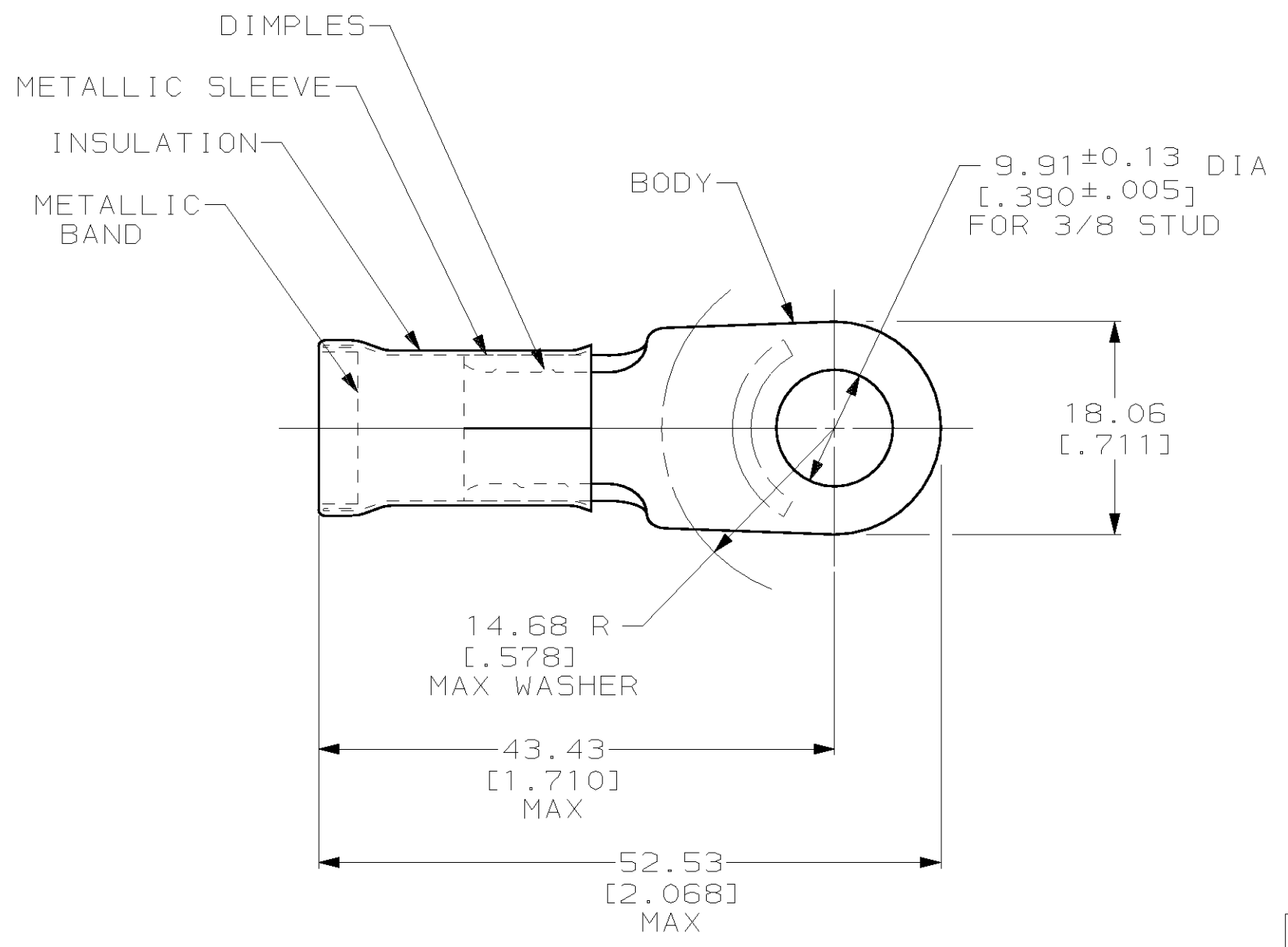

- 1 MATERIAL THK: 1.45 ± 0.08 [.057 ± .003]
- 2 WIRE INSULATION DIA: 12.83 [.505] MAX
- 3 TIN PL 0.00254 [.000100] MIN THK PER ASTM B-545
- 4 GOLD PL 0.00127 [.000050] MIN EXT THK PER MIL-G-45204 OVER NICKEL PL 0.00076 [.000030] MIN EXT THK PER QQ-N-290

<u>BODY:</u> COPPER PER ASTM B-152 <u>INSULATION:</u> PVC <u>COLOR:</u> RED <u>METALLIC SLEEVE:</u> COPPER PER ASTM B-152 <u>METALLIC BAND:</u> STEEL PER ASTM A-109	<b>OBSOLETE</b> <del>2-322055-1</del>
	322055
MATERIAL & FINISH	
AMP PART NUMBER	

# AMP INCORPORATED CUSTOMER SERVICE SYSTEMS

FOR ADDITIONAL PRODUCT INFORMATION OR COPIES OF DRAWINGS AND TECHNICAL DOCUMENTS	PRODUCT INFORMATION CENTER 1-800-522-6752	RECOMMENDED OPERATING TEMPERATURE: 105°C MAX
FOR APPLICATION TOOLING INFORMATION	TOOLING ASSISTANCE CENTER 1-800-722-1111	VOLTAGE RATING: NOT APPLICABLE
FOR ORDER ENTRY	1-800-526-5142	WIRE CROSS SECTIONAL AREA RANGE: 26.7-42.4mm <sup>2</sup> [52,600-83,700] CIR MILS SOLID OR STRANDED

THIS DRAWING IS A CONTROLLED DOCUMENT.

DIMENSIONS: mm [INCHES]	TOLERANCES UNLESS OTHERWISE SPECIFIED:
	0 PLC ±-
	1 PLC ±-
	2 PLC ±0.20 [.008]
	3 PLC ±-
	4 PLC ±-
	ANGLES ±-
MATERIAL SEE TABLE	FINISH SEE TABLE

DWN DK SCHRUM 03NOV97	AMP Incorporated Harrisburg, PA 17105-3608
CHK MJ SPICER 03NOV97	
APVD JL MECKLEY 03NOV97	
PRODUCT SPEC	
APPLICATION SPEC	NAME TERMINAL, RING TONGUE, AMPLI-BOND™, WIRE SIZE: 2 AWG
WEIGHT -	SIZE A3
CUSTOMER DRAWING	CAGE CODE 00779
	DRAWING NO C- 322055
	RESTRICTED TO -
	SCALE 2:1
	SHEET 1 OF 1
	REV J