

# PART NUMBER CODING SWT204-UP N-S01-UU-UU

## PLATING

T = .000015" MIN NICKEL UNDERPLATE, .000040" MIN PURE TIN, BRIGHT OVERALL (NOTE 7)  
P = .000040" MIN NICKEL UNDERPLATE, GOLD FLASH OVERALL.

REVISIONS				
REV.	ECO. NO	DESCRIPTION	DATE	BY
A	2236	INITIAL RELEASE	05/24/2011	LH

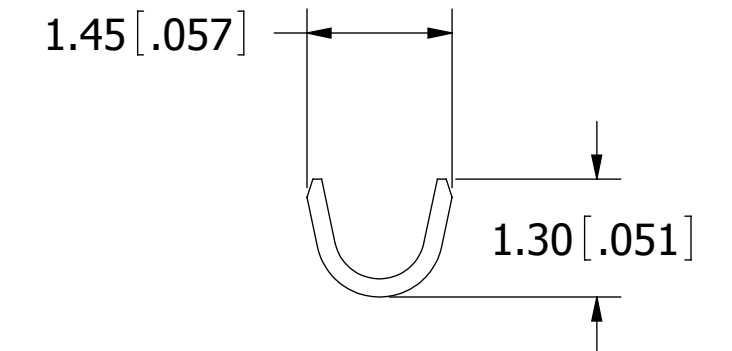
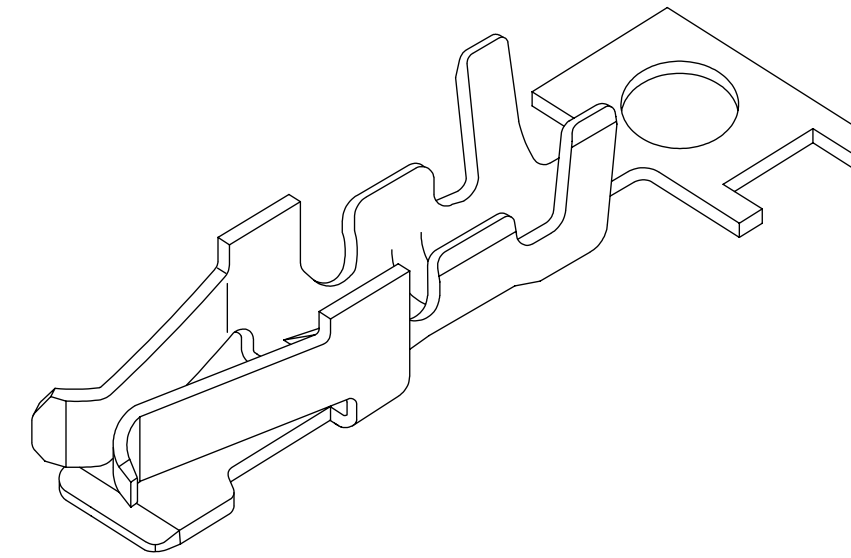
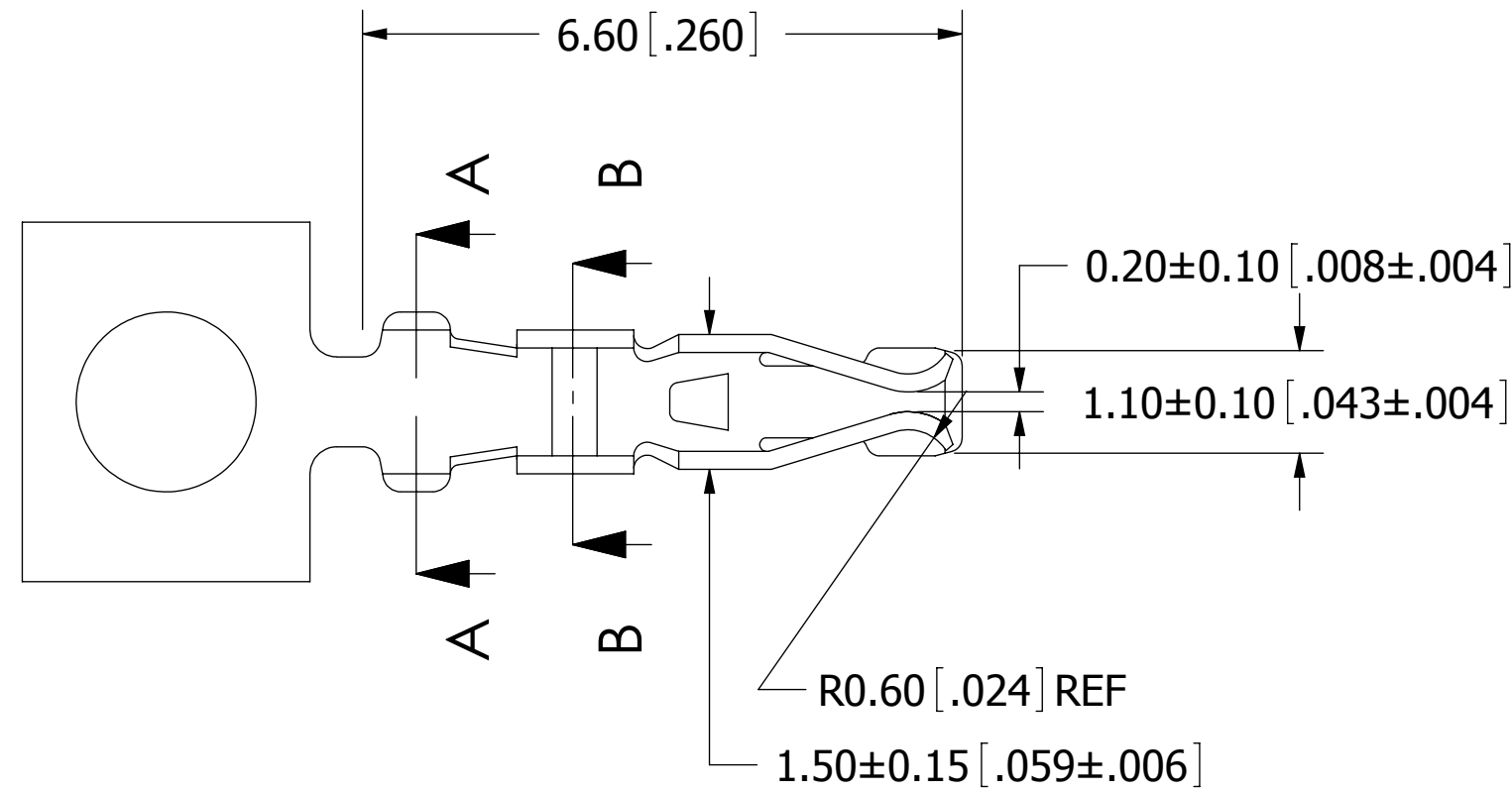

SECTION B-B

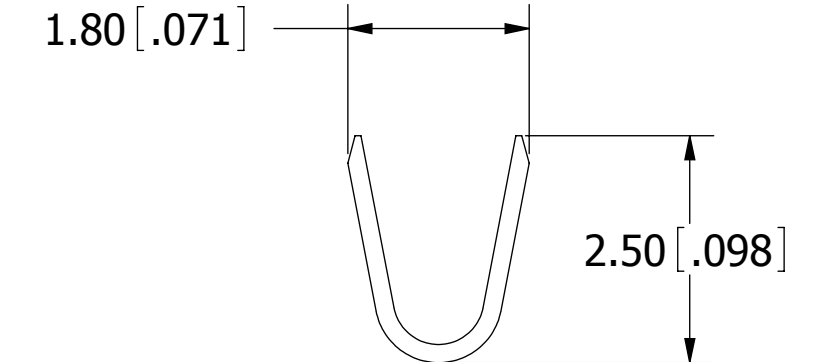
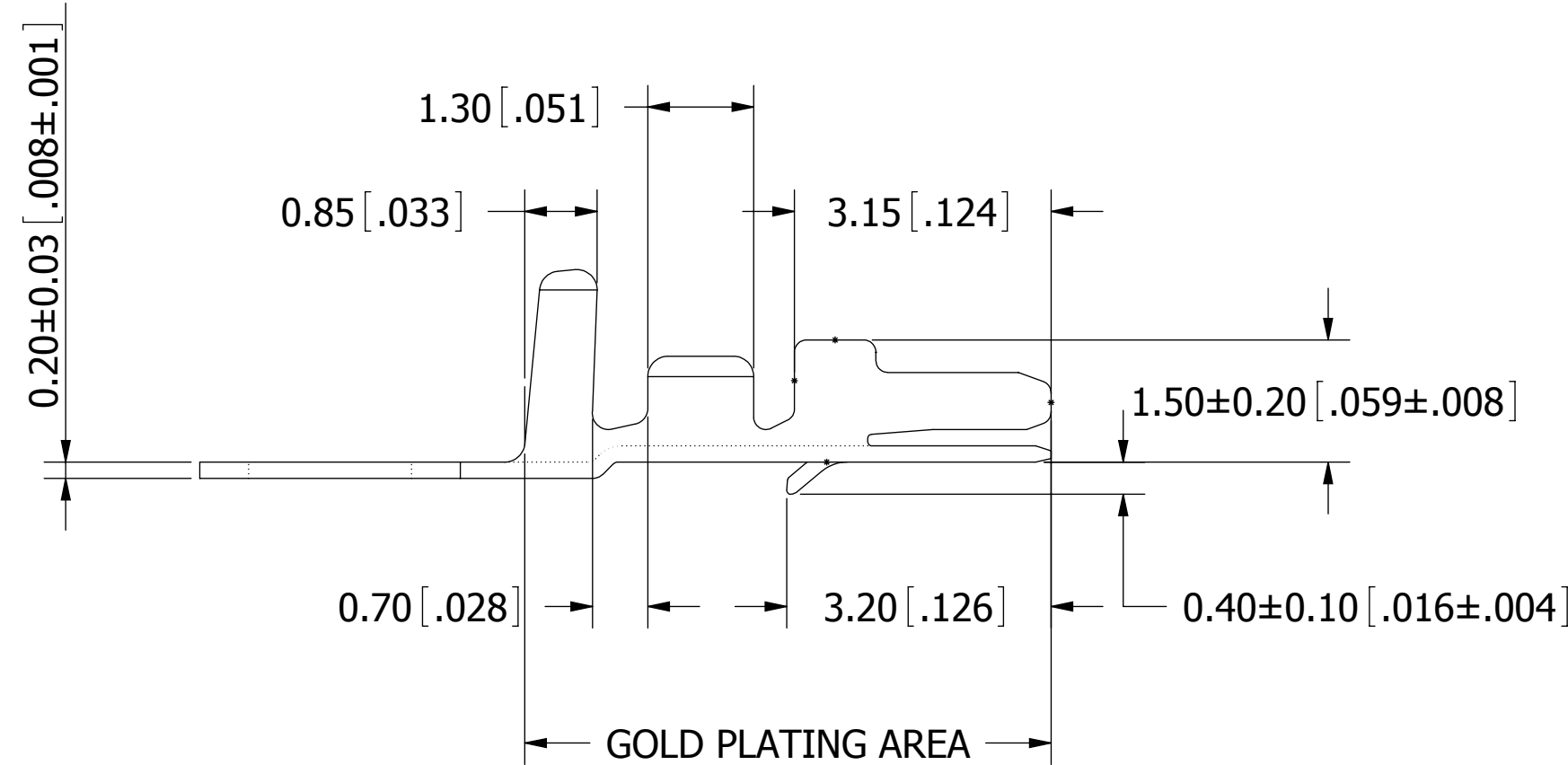

SECTION A-A

### NOTES:

1. MATERIAL: PHOSPHOR BRONZE.
2. PLATING: SEE PART NUMBER CODING.
3. WIRE RANGE: AWG #22 - #26.
4. INSULATION O.D.:  $\phi$  1.35mm ~  $\phi$  1.70mm.
5. QUANTITY PER REEL = 10,000 PIECES.
6. USED IN SWH204 SERIES HOUSING.
7. PLATING BEFORE STAMPING/FORMING.

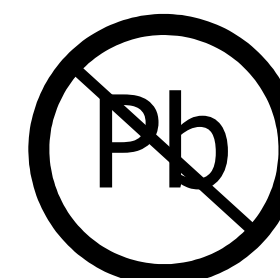

RoHS COMPLIANT

UNLESS OTHERWISE SPECIFIED: DIMENSIONS ARE IN MM[INCHES]	DRAWN	DATE	NAME	
		05/24/2011	LH	
TOLERANCES: ANGULAR: .X= ± 0.3 [.01] .XX= ± 0.30 [.012]	<small>THE INFORMATION HEREIN CONTAINS PROPRIETARY INFORMATION OF SULLINS ELECTRONICS AND IS NOT TO BE REPRODUCED, USED OR DISCLOSED TO OTHERS FOR ANY PURPOSE EXCEPT AS SPECIFICALLY AUTHORIZED IN WRITING BY AN OFFICER OF SULLINS ELECTRONICS.</small>			
	TITLE CRIMP TERMINAL - SWH 204			
PART NUMBER SWT204-UP_N-S01-UU-UU				SIZE C
INTERPRET DIMENSIONS AND TOLERANCING PER: ASME Y14.5M-2009		CAGE CODE 54453	DWG. NO. 11627	REV A
		SCALE: 12:1	SHEET 1 OF 1	